



CONERGY

Standalone inverters | Technical data

Conergy ISA 20K/30K hybrid

Conergy ISA hybrid standalone inverters enable power to be supplied to remote areas that are not connected to the public electricity grid. The inverter controls the battery charging, which is done primarily using solar generators, and convert the battery electricity into grid-compatible AC power for supplying electricity. A diesel generator can be integrated within the power management system, which can take over the electricity generation without interrupting the power

supply if needed (hybrid system). All Conergy ISA hybrid stand-alone inverters have an internal MPPT (Maximum Power Point Tracking) charge controller. This controls the charging and power management and provides up to 20 % more energy output. Many years of international experience and innovative system enhancements ensure that Conergy ISA hybrid inverters are world leaders concerning system efficiency, reliability and service.



Maximum system efficiency with MPPT

Conergy ISA hybrid inverters use charge controllers with processor-controlled MPPT, which is normally only a standard for grid-connected inverters. This technology provides the battery always with the maximum power available. The integrated DC/DC regulator charges the battery at its voltage level. This faster, optimised battery charging supplies up to 20 % more energy.

Battery and power management

The integrated MPPT charge controller regulates the battery and power management. The battery's state of charge is constantly monitored by a current-compensating voltage meter that also compensates for the battery temperature. If there is insufficient solar energy, the process controller switches on a diesel generator that supplies the consumers with AC power without any interruption. The diesel generator simultaneously charges the batteries via the intermediate inverter, which in this case operates as a rectifier.

Robust and reliable

The components used in Conergy ISA hybrid inverters are designed for maximum reliability in order to easily withstand continuous heavy loads over many years. This is indicated by:

- | Electrolytic capacitors with a service life of up to 30,000 hours under full load
- | Output stages with five-fold voltage resistance
- | An operating temperature range between 0 and +60 °C
- | High-quality ball-bearing fans

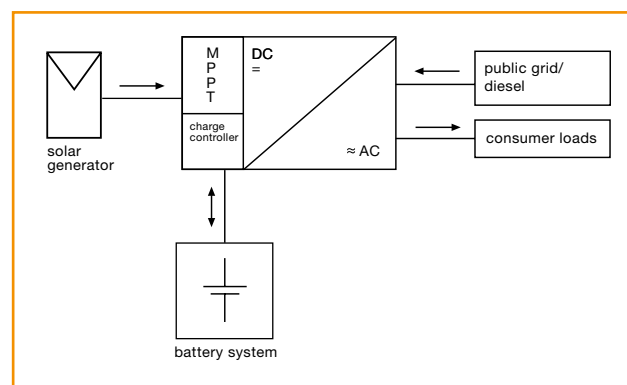

PHOTOVOLTAICS



CONERGY

Standalone inverters | Technical data

Conergy ISA 20K/30K hybrid

	Conergy ISA 20K hybrid	Conergy ISA 30K hybrid
Solar generator		
Solar generator power (25 °C recommended)	26,000 Wp	40,000 Wp
DC input power (40 °C)	21,500 W	33,000 W
Operation mode	MPP tracking (microprocessor)	MPP tracking (microprocessor)
Solar generator voltage range ($V_{p_{min}}-V_{oc_{max}}$)	145–350 V _{DC}	290–700 V _{DC}
Battery (Pb) 25 °C		
Battery configuration (cells in series)	60	120
Battery voltage (rated)	120 V	240 V
Inverter switch-on voltage	125 V	250 V
Inverter turn-off voltage	111 V	222 V
Gassing voltage	145 V	290 V
Continuous charging voltage	140 V	280 V
Overvoltage threshold	155 V	310 V
Temperature sensor	For charge threshold compensation (–0,003 V/°C per cell)	
Charge control	I/U	I/U
Max. continuous charging current from solar generator	165 A	83 A
Max. continuous discharge current	175 A	130 A
Charge controller efficiency	94–98 % (10–100 % solar generator power)	
AC input		
Voltage range	305–469 V _{AC}	305–469 V _{AC}
Frequency range	48–52 Hz	48–52 Hz
Charging capacity of diesel generator/grid	16,000 W	24,000 W
Remote control	Diesel generator start/stop	Diesel generator start/stop
Diesel generator power (recommended)	40,000 VA	60,000 VA
Operation mode		
Load supply from inverter	With charged battery	With charged battery
Battery charging/load supply from diesel generator/grid	With battery undervoltage or manually	With battery undervoltage or manually
Bypass-operation	When inverter off or manually	When inverter off or manually
Inverter output		
Output voltage	230/400 V _{AC}	230/400 V _{AC}
Output frequency	50 Hz (true sinewave)	50 Hz (true sinewave)
Distortion factor	< 3 %	< 3 %
Inverter efficiency	90–92 % (15–100 % output power)	90–92 % (15–100 % output power)
Power factor Cos Phi	0–1 (load-dependent)	0–1 (load-dependent)
Continuous output power 40 °C	20,000 VA	30,000 VA
Continuous output power 50 °C	13,500 VA	20,000 VA
Peak output power 40 °C (10 sec)	30,000 VA	45,000 VA
Peak output power 50 °C (10 sec)	20,000 VA	30,000 VA
General data		
Fuses	Solar generator (against reverse current), battery, diesel generator/grid, load	
Surge voltage protection (varistors and spark gaps)	Solar generator, battery	Solar generator, battery
Standards	EN 61000–6–1: 2001, EN 61000–6–2: 2001, 61000–6–3: 2001 + A11: 2004 EN 61000–6–4: 2001, EN 61000–3–2: 2000, EN 50178: 1997	
Ambient temperature range	0–40 °C/40–60 °C with derating	0–40 °C/40–60 °C with derating
Humidity	0–95 % non-condensing	0–95 % non-condensing
Protection type	IP 20	IP 20
Dimensions (W x H x D)	610 x 1,800 x 800 mm	610 x 1,800 x 800 mm
Weight	Approx. 460 kg	Approx. 540 kg
Housing	Floor-mounted	Floor-mounted

Available from: