



CONERGY

Standalone inverters | Technical data

Conergy ISA 4000/6000/12K hybrid

Conergy ISA hybrid standalone inverters enable power to be supplied to remote areas that are not connected to the public electricity grid. The inverter controls the battery charging, which is done primarily using solar generators, and convert the battery electricity into grid-compatible AC power for supplying electricity. A diesel generator can be integrated within the power management system, which can take over the electricity generation without interrupting

the power supply if needed (hybrid system). All Conergy ISA hybrid stand-alone inverters have an internal MPPT (Maximum Power Point Tracking) charge controller. This controls the charging and power management and provides up to 20% more energy output. Many years of international experience and innovative system enhancements ensure that Conergy ISA hybrid inverters are world leaders concerning system efficiency, reliability and service.



Maximum system efficiency with MPPT

Conergy ISA hybrid inverters use charge controllers with processor-controlled MPPT, which is normally only a standard for grid-connected inverters. This technology provides the battery always with the maximum power available. The integrated DC/DC regulator charges the battery at its voltage level. This faster, optimised battery charging supplies up to 20% more energy.

Battery and power management

The integrated MPPT charge controller regulates the battery and power management. The battery's state of charge is constantly monitored by a current-compensating voltage meter that also compensates for the battery temperature. If there is insufficient solar energy, the process controller switches on a diesel generator that supplies the consumers with AC power without any interruption. The diesel generator simultaneously charges the batteries via the intermediate inverter, which in this case operates as a rectifier.

Robust and reliable

The components used in Conergy ISA hybrid inverters are designed for maximum reliability in order to easily withstand continuous heavy loads over many years. This is indicated by:

- | Electrolytic capacitors with a service life of up to 30,000 hours under full load
- | Output stages with five-fold voltage resistance
- | An operating temperature range between 0 and +60 °C
- | High-quality ball-bearing fans

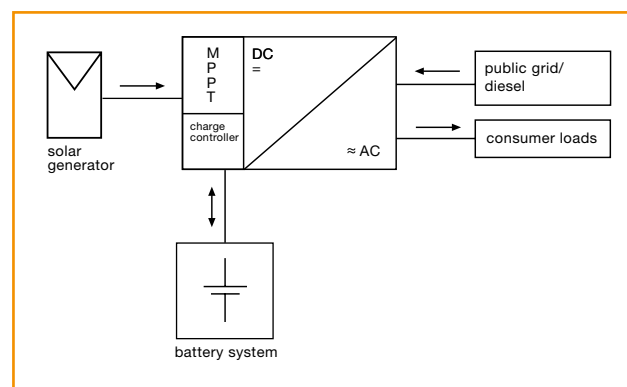

PHOTOVOLTAICS



CONERGY

Standalone inverters | Technical data

Conergy ISA 4000/6000/12K hybrid

	Conergy ISA 4000 hybrid	Conergy ISA 6000 hybrid	Conergy ISA 12K hybrid
Solar generator			
Solar generator power (25 °C recommended)	5.200 Wp	7.800 Wp	15.500 Wp
DC input power (40 °C)	4.500 W	6.500 W	13.000 W
Operation mode	MPP tracking (microprocessor)		
Solar generator voltage range ($V_{Pmin}-V_{Pmax}$)	58–150 V _{DC}	145–350 V _{DC}	145–350 V _{DC}
Battery (Pb) 25 °C			
Battery configuration (cells in series)	24	60	60
Battery voltage (rated)	48 V	120 V	120 V
Inverter switch-on voltage	50 V	125 V	125 V
Inverter turn-off voltage	44 V	111 V	111 V
Gassing voltage	58 V	145 V	145 V
Continuous charging voltage	56 V	140 V	140 V
Overvoltage threshold	62 V	155 V	155 V
Temperature sensor	For charge threshold compensation (–0,003 V/°C per cell)		
Charge control	I/U		
Max. continuous charging current from solar generator	83 A	50 A	100 A
Max. continuous discharge current	100 A	55 A	110 A
Charge controller efficiency	94–98 % (10–100 % solar generator power)		
AC input			
Voltage range	176–271 V _{ac}	176–271 V _{ac}	176–271 V _{ac}
Frequency range	48–52 Hz	48–52 Hz	48–52 Hz
Charging capacity of diesel generator/grid	3,200 W	4,800 W	9.600 W
Remote control	Diesel generator start/stop		
Diesel generator power (recommended)	8,000 VA	12,000 VA	24,000 VA
Operation mode			
Load supply from inverter	With charged battery		
Battery charging/load supply from diesel generator/grid	With battery undervoltage or manually		
Bypass-operation	When inverter off or manually		
Inverter output			
Output voltage	230 V _{ac}		
Output frequency	50 Hz (true sinewave)		
Distortion factor	< 3 %		
Inverter efficiency	90–92 % (15–100 % output power)		
Power factor Cos Phi	0–1 (load-dependent)		
Continuous output power 30 °C	4,000 VA	6,000 VA	12,000 VA
Continuous output power 40 °C	3,200 VA	4,000 VA	8,000 VA
Peak output power 30 °C (10 sec)	6,000 VA	9,000 VA	18,000 VA
Peak output power 40 °C (10 sec)	4,000 VA	6,000 VA	12,000 VA
General data			
Fuses	Solar generator (against reverse current), battery, diesel generator/grid, load		
Surge voltage protection (varistors and spark gaps)	Solar generator, grid (diesel generator)		
Standards	EN 61000–6–1: 2001, EN 61000–6–2: 2001, 61000–6–3: 2001 + A11: 2004 EN 61000–6–4: 2001, EN 61000–3–2: 2000, EN 50178: 1997		
Ambient temperature range	0–40 °C/40–60 °C with derating		
Humidity	0–95 % non-condensing		
Protection type	IP 20		
Dimensions (W x H x D)	354 x 587 x 657 mm	354 x 587 x 657 mm	454 x 750 x 821 mm
Weight	Approx. 65 kg	Approx. 85 kg	Approx. 149 kg
Housing	Floor-mounted		

Available from: